



photomechanics



PROJECTION AND LIGHT SELECTION SYSTEMS

CARTS

IMPROVE THE
CONVENIENCE / SPEED / ACCURACY
OF ORDER PICKING



APPLICATION



Delivery services



Wholesale / retail



Marketplaces



Fulfillment



Online stores



Pharmaceutical distribution



Cosmetics distribution

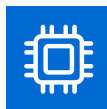

Electronic devices distribution

PICKING CART with PTL

ONE-SIDE
FM-2 PTL-6



PUT TO LIGHT MODULE

Contains:



3-bit segment display



"+" and "-" buttons



RS-485 interface



"OK" button



Number of modules

6

LOAD CAPACITY

Single box weight

25 kg

Per shelf

80 kg

Total per cart

160 kg

DIMENSIONS

Height

1500 mm

Depth

800 mm

Width

1350 mm

CONTENTS OF DELIVERY

Cart with PTL + wireless or stationary scanner

2 batteries

+ charger

Accessory

(on request)

ELECTRIC EQUIPMENT

Controller	Single-board computer Orange Pi 4 LTS, with Wi-Fi
Cart operating system	Linux
Main display	Color touch display 5" /7" /10" /12"
Batteries (2)	LiFePO4 24V 24Ah NETER (LFP8-18-20P6) with container, charger (!), charge monitoring and indication system
Barcode scanner	Barcode scanner MERTECH 8500 P2D Mirror Black + option to connect second scanner
	Wireless finger scanner

MANUFACTURING MATERIALS

Shelves, racks	Aluminum
Clamping elements, handles, skirting, base	Steel
Coating	Polymer powder *Color as agreed with client (by default grey RAL 9006)

ADD-ON COMPONENTS

Wheel legs	MRAE 125 K, elastic polyurethane
Side wheels	Fixed
Front and rear wheels	Swivel with lock



PICKING CART with PTL

ONE-SIDE
FM-4 PTL-12



PUT TO LIGHT MODULE

Contains:

- ✓ 3-bit segment display
- ✓ RS-485 interface
- ✓ "+" and "-" buttons
- ✓ "OK" button

Number of modules	12
-------------------	----



LOAD CAPACITY

Single box weight	20 kg
Per shelf	80 kg
Total per cart	240 kg

DIMENSIONS

Height	1700 mm <small>*1940 with camera bracket</small>
Depth	790 mm
Width	800 mm

CONTENTS OF DELIVERY

Cart with PTL + wireless or stationary scanner	
2 batteries	+ charger
Accessory	(on request)

ELECTRIC EQUIPMENT

Controller	Single-board computer Orange Pi 4 LTS, with Wi-Fi
Cart operating system	Linux
Main display	Color touch display 5" /7" /10" /12"
Batteries (2)	LiFePO4 24V 24Ah NETER (LFP8-18-20P6) with container, charger (!), charge monitoring and indication system
Barcode scanner	Barcode scanner MERTECH 8500 P2D Mirror Black + option to connect second scanner
	Wireless finger scanner

MANUFACTURING MATERIALS

Shelves, racks	Aluminum
Clamping elements, handles, skirting, base	Steel
Coating	Polymer powder *Color as agreed with client (by default grey RAL 9006)

ADD-ON COMPONENTS

Wheel legs	MRAE 125 K, elastic polyurethane
Side wheels	Fixed
Front and rear wheels	Swivel with lock



PICKING CART with PTL

TWO-SIDE
FM-1 PTL-6



PUT TO LIGHT MODULE

Contains:

- ✓ 3-bit segment display
- ✓ "+" and "-" buttons
- ✓ RS-485 interface
- ✓ "OK" button

Number of modules — 6



LOAD CAPACITY

Single box weight	—	50 kg
Per shelf	—	150 kg
Total per cart	—	150 kg

DIMENSIONS

Height	—	1250 mm
Depth	—	600 mm
Width	—	1700 mm

CONTENTS OF DELIVERY

Cart with PTL + wireless or stationary scanner		
2 batteries	—	+ charger
Accessory	—	(on request)

ELECTRIC EQUIPMENT

Controller	Single-board computer Orange Pi 4 LTS, with Wi-Fi
Cart operating system	Linux
Main display	Color touch display 5" /7" /10" /12"
Batteries (2)	LiFePO4 24V 24Ah NETER (LFP8-18-20P6) with container, charger (!), charge monitoring and indication system
Barcode scanner	Barcode scanner MERTECH 8500 P2D Mirror Black + option to connect second scanner
	Wireless finger scanner

MANUFACTURING MATERIALS

Shelves, racks	Aluminum
Clamping elements, handles, skirting, base	Steel
Coating	Polymer powder *Color as agreed with client (by default grey RAL 9006)

ADD-ON COMPONENTS

Wheel legs	MRAE 125 K, elastic polyurethane
Side wheels	Fixed
Front and rear wheels	Swivel with lock

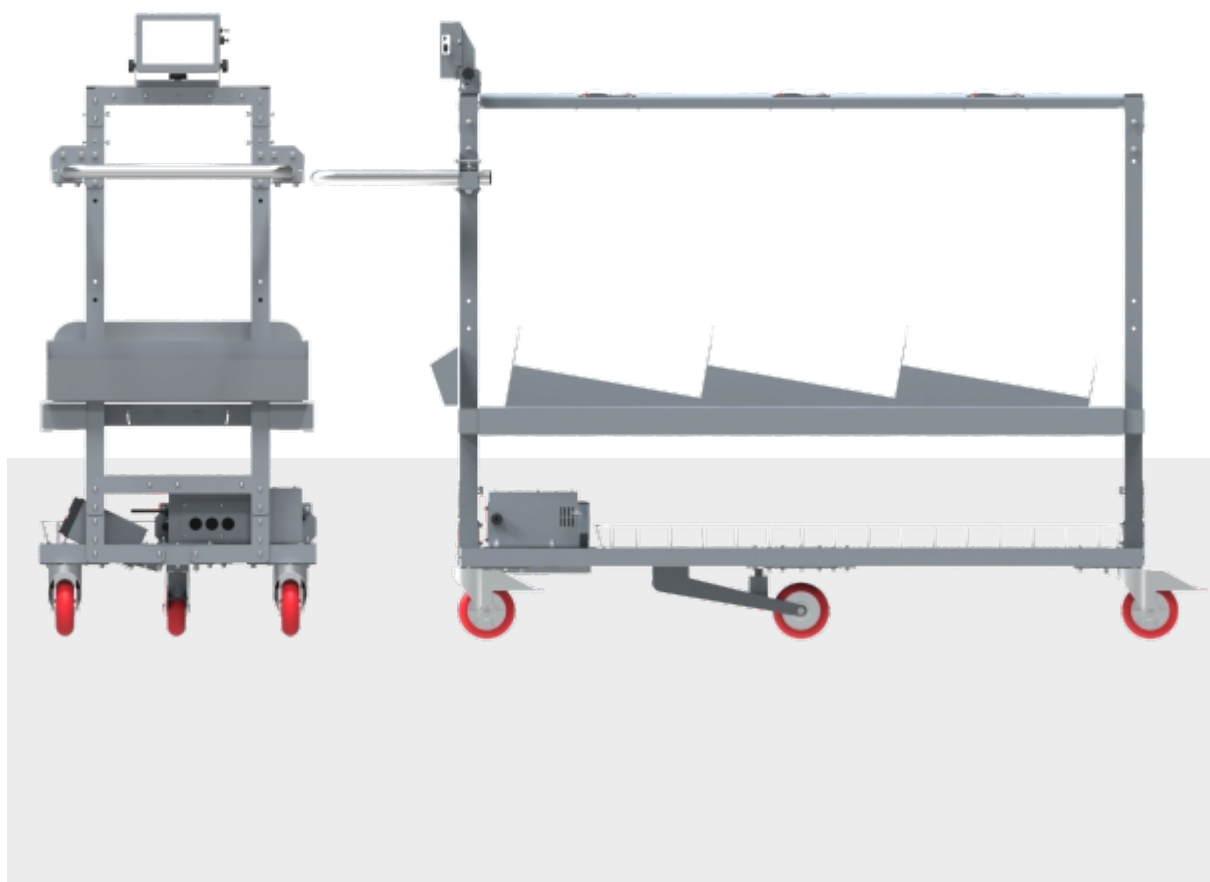

PICKING CART with PTL

TWO-SIDE
FM-2 PTL-8



PUT TO LIGHT MODULE

Contains:

✓ 3-bit segment display

✓ RS-485 interface

✓ "+" and "-" buttons

✓ "OK" button

Number of modules — 8



LOAD CAPACITY

Single box weight — 25 kg

Per shelf — 100 kg

Total per cart — 200 kg

DIMENSIONS

Height — 1600 mm

Depth — 700 mm

Width — 1100 mm

CONTENTS OF DELIVERY

Cart with PTL + wireless or stationary scanner

2 batteries — + charger

Accessory — (on request)

ELECTRIC EQUIPMENT

Controller	Single-board computer Orange Pi 4 LTS, with Wi-Fi
Cart operating system	Linux
Main display	Color touch display 5" /7" /10" /12"
Batteries (2)	LiFePO4 24V 24Ah NETER (LFP8-18-20P6) with container, charger (!), charge monitoring and indication system
Barcode scanner	Barcode scanner MERTECH 8500 P2D Mirror Black + option to connect second scanner
	Wireless finger scanner

MANUFACTURING MATERIALS

Shelves, racks	Aluminum
Clamping elements, handles, skirting, base	Steel
Coating	Polymer powder *Color as agreed with client (by default grey RAL 9006)

ADD-ON COMPONENTS

Wheel legs	MRAE 125 K, elastic polyurethane
Side wheels	Fixed
Front and rear wheels	Swivel with lock

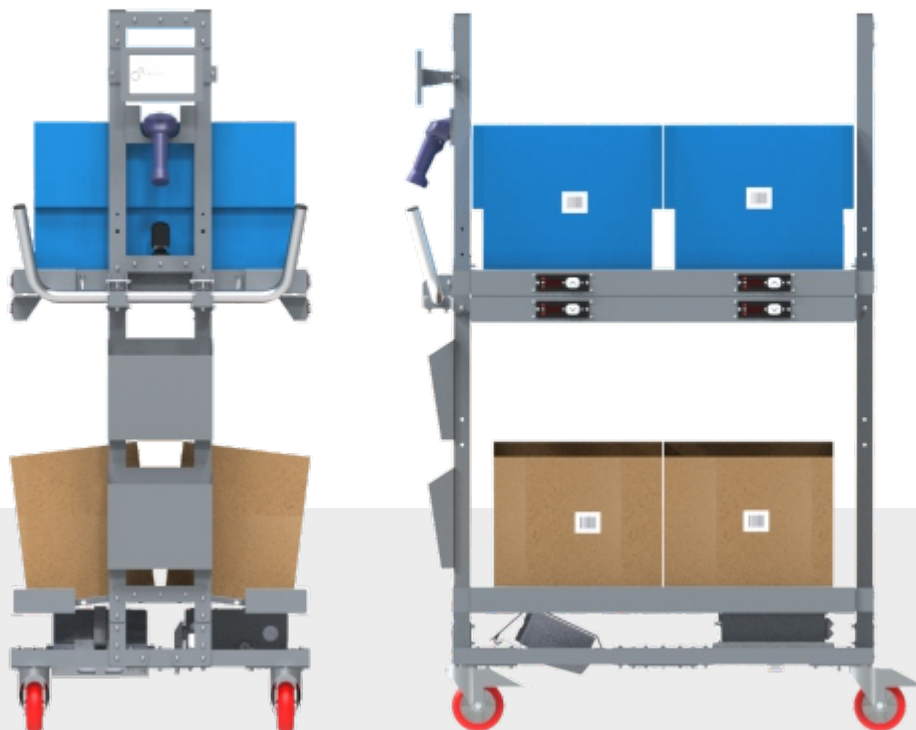

PICKING CART with PTL

TWO-SIDE

PMA-PTLC-M-12



PUT TO LIGHT MODULE

Contains:

✓ 3-bit segment display

✓ RS-485 interface

✓ "+" and "-" buttons

✓ "OK" button



Number of modules

18

LOAD CAPACITY

Single box weight

25 kg

Per shelf

80 kg

Total per cart

240 kg

DIMENSIONS

Height

1350 mm

Depth

850 mm

Width

750 mm

CONTENTS OF DELIVERY

Cart with PTL + wireless or stationary scanner

2 batteries

+ charger

Accessory

(on request)

ELECTRIC EQUIPMENT

Controller	Single-board computer Orange Pi 4 LTS, with Wi-Fi
Cart operating system	Linux
Main display	Color touch display 5" /7" /10" /12"
Batteries (2)	LiFePO4 24V 24Ah NETER (LFP8-18-20P6) with container, charger (!), charge monitoring and indication system
Barcode scanner	Barcode scanner MERTECH 8500 P2D Mirror Black + option to connect second scanner
	Wireless finger scanner

MANUFACTURING MATERIALS

Shelves, racks	Aluminum
Clamping elements, handles, skirting, base	Steel
Coating	Polymer powder *Color as agreed with client (by default grey RAL 9006)

ADD-ON COMPONENTS

Wheel legs	MRAE 125 K, elastic polyurethane
Side wheels	Fixed
Front and rear wheels	Swivel with lock



PICKING CART

TWO-SIDE



LOAD CAPACITY

Single box weight	—	25 kg
Per shelf	—	80 kg
Total per cart	—	240 kg

DIMENSIONS

Height	—	1350 mm
Depth	—	850 mm
Width	—	750 mm

MANUFACTURING MATERIALS

Shelves, racks	—	Aluminum
Clamping elements, handles, skirting, base	—	Steel
Coating	—	Polymer powder *Color as agreed with client (by default grey RAL 9006)

ADD-ON COMPONENTS

Wheel legs	—	MRAE 125 K, elastic polyurethane
Side wheels	—	Fixed
Front and rear wheels	—	Swivel with lock



Light mobile TABLE CART



LOAD CAPACITY

Single box weight	—	20 kg
-------------------	---	-------

Per shelf	—	20 kg
-----------	---	-------

Total per cart	—	50 kg
----------------	---	-------

DIMENSIONS

Height	—	600 mm
--------	---	--------

Depth	—	850 mm
-------	---	--------

Width	—	450 mm
-------	---	--------

MANUFACTURING MATERIALS

Shelves, racks	—	Aluminum
Clamping elements, handles, skirting, base	—	Steel
Coating	—	Polymer powder *Color as agreed with client (by default grey RAL 9006)

ADD-ON COMPONENTS

Wheel legs	—	MRAE 125 K, elastic polyurethane
Side wheels	—	Fixed
Front and rear wheels	—	Swivel with lock

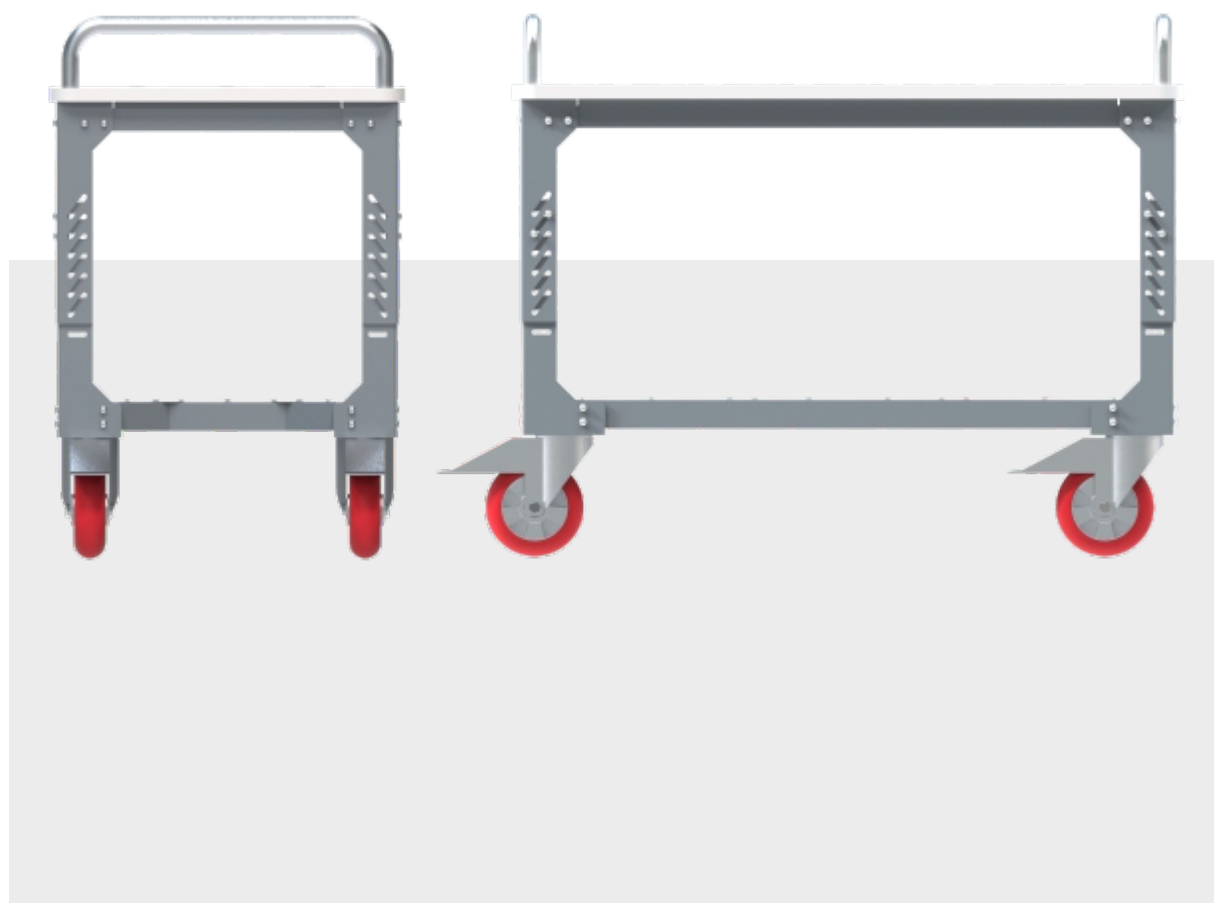

Large mobile CONTROL STATIONS for two operators

TWO-SIDE



LOAD CAPACITY

Single box weight	—	30 kg
Per shelf	—	50 kg
Per table board	—	250 kg
Total per cart	—	350 kg

DIMENSIONS

Height	—	1000 mm <small>*with ruler</small>
Depth	—	1420 mm
Width	—	1350 mm

MANUFACTURING MATERIALS

Shelves, racks	—	Aluminum
Clamping elements, handles, skirting, base	—	Steel
Coating	—	Polymer powder *Color as agreed with client (by default grey RAL 9006)

ADD-ON COMPONENTS

Wheel legs	—	MRAE 125 K, elastic polyurethane
Side wheels	—	Fixed
Front and rear wheels	—	Swivel with lock

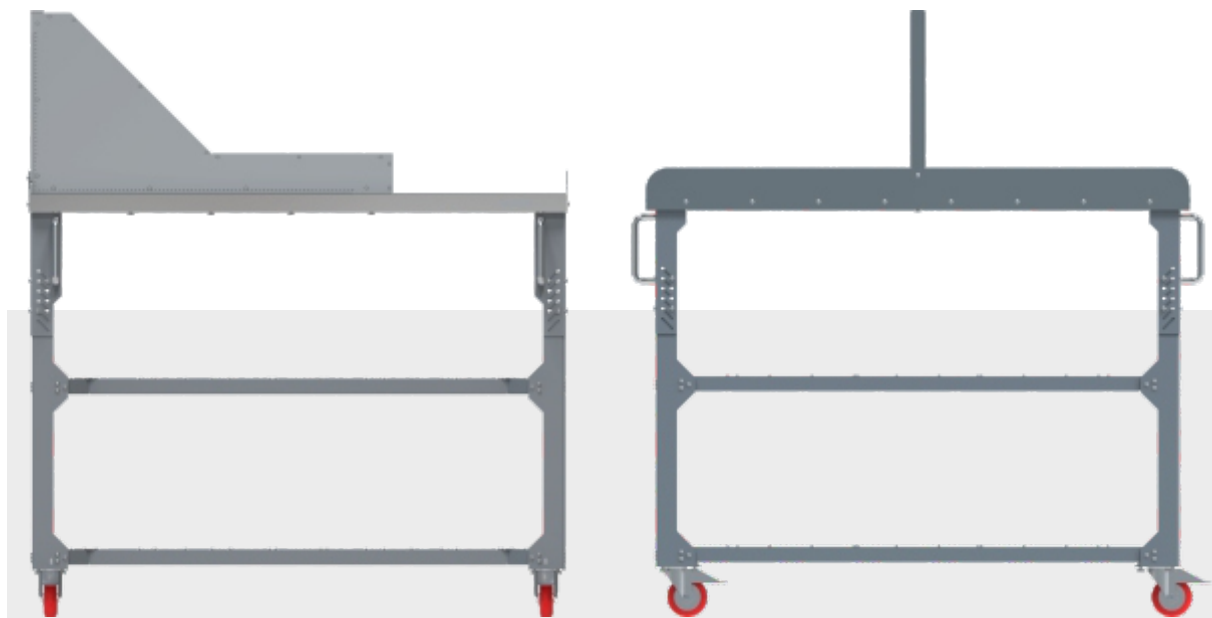

Mobile PACKING STATION

for two operators



LOAD CAPACITY

Single box weight	—	30 kg
Per shelf	—	50 kg
Per table board	—	250 kg
Total per cart	—	350 kg

DIMENSIONS

Height	—	820 mm *990 with ruller
Depth	—	1200 mm
Width	—	730 mm

MANUFACTURING MATERIALS

Shelves, racks	—	Aluminum
Clamping elements, handles, skirting, base	—	Steel
Coating	—	Polymer powder *Color as agreed with client (by default grey RAL 9006)

ADD-ON COMPONENTS

Wheel legs	—	MRAE 125 K, elastic polyurethane
Side wheels	—	Fixed
Front and rear wheels	—	Swivel with lock

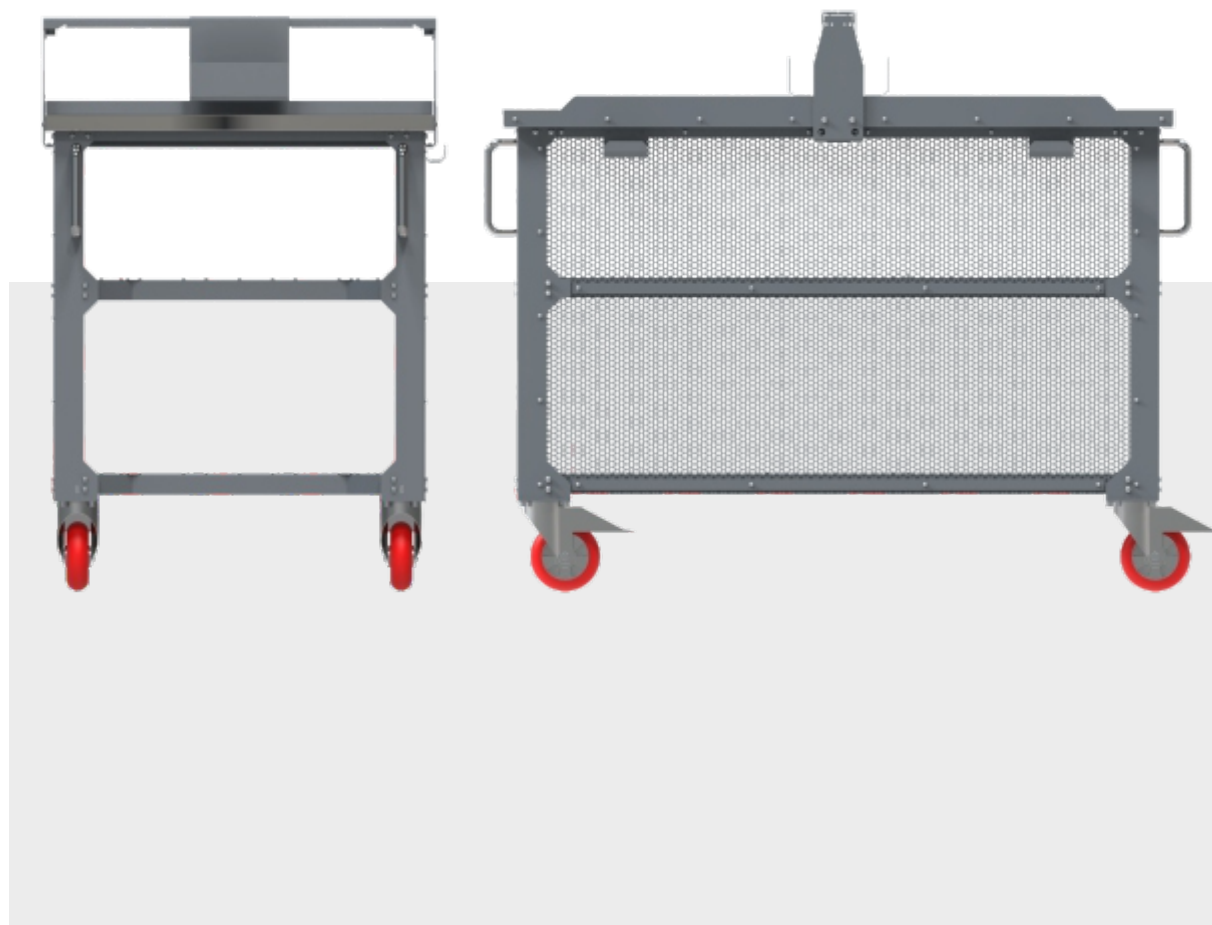

Stationary PACKING STATION for two operators



LOAD CAPACITY

Single box weight	—	30 kg
-------------------	---	-------

Per shelf	—	50 kg
-----------	---	-------

Per table board	—	250 kg
-----------------	---	--------

Total per cart	—	350 kg
----------------	---	--------

DIMENSIONS

Height	—	870 mm *1610 with ruller
--------	---	-----------------------------

Depth	—	1525 mm
-------	---	---------

Width	—	1200 mm
-------	---	---------

MANUFACTURING MATERIALS

Shelves, racks	—	Aluminum
Clamping elements, handles, skirting, base	—	Steel
Coating	—	Polymer powder *Color as agreed with client (by default grey RAL 9006)

ADD-ON COMPONENTS

Wheel legs	—	MRAE 125 K, elastic polyurethane
Side wheels	—	Fixed
Front and rear wheels	—	Swivel with lock

